

STANDARD SPECIFICATIONS
MANUFACTURE
 ASTM C 1433 (SPECIAL DESIGN)
 AASHTO M-259, M-273

JOINT SPECIFICATIONS
(FLEXIBLE SEALANT)
 ASTM C 990
 AASHTO M-198-B

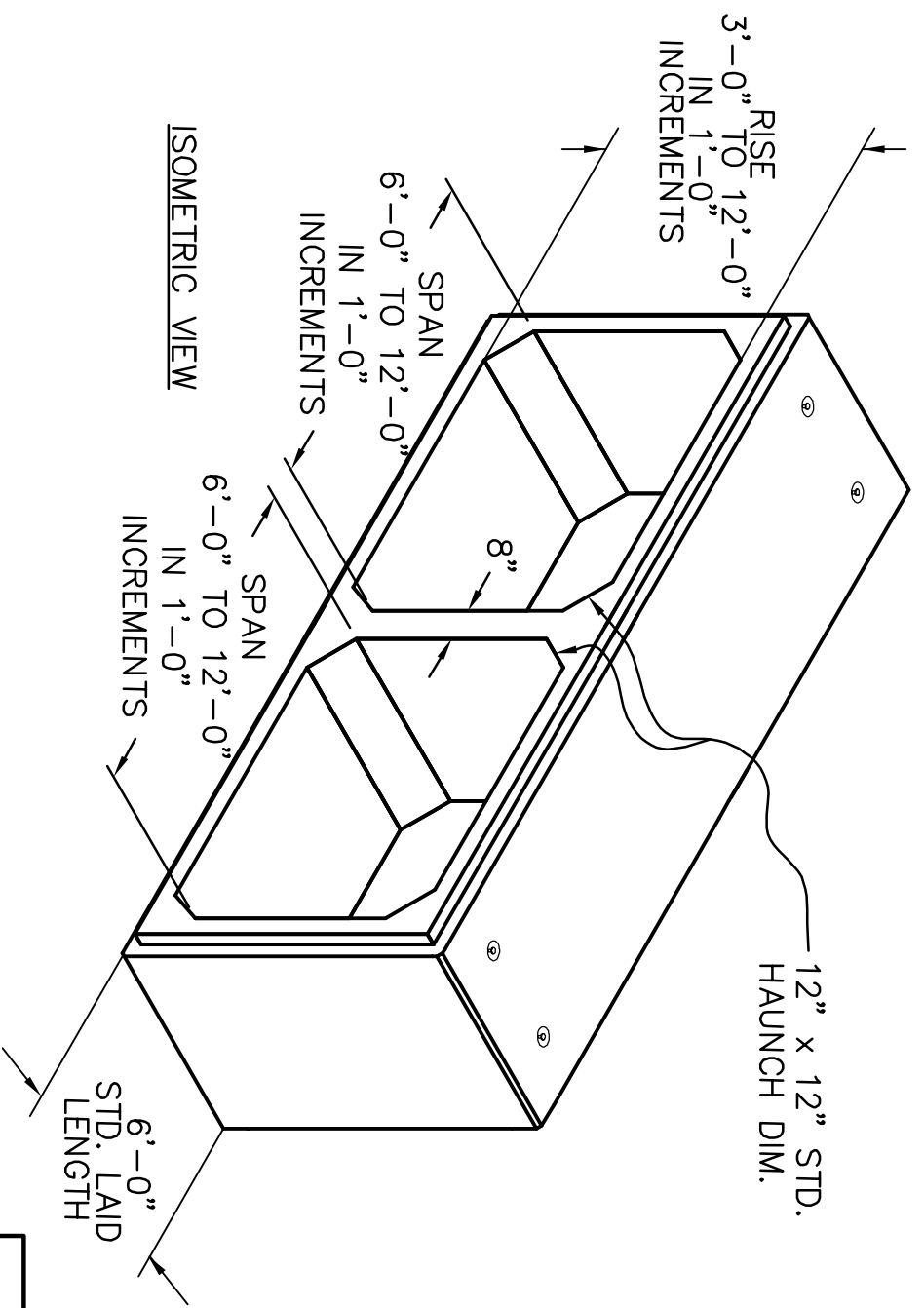

- WALL, TOP SLAB, AND BOTTOM SLAB THICKNESS WILL VARY, DEPENDING UPON BOX SIZE AND DESIGN CRITERIA
- SCALE: NONE



725 BRYAN STOCK TRAIL
 CASPER, WYOMING 8260
 Phone: (307)265-3100
 Fax: (307)265-0013

| | |
|-------------------------------------|---------------|
| DRAWN BY: MDB | DATE: 2-18-09 |
| DOUBLE CELL BOX CULVERTS | |